

PowerBar

Insulated Conductor Bar Systems

600 VOLTS - A.C., 250 VOLTS D.C.

INVERTED V-BAR - for new applications

- The inverted “V” shape of the conductor bar provides more overall strength
- The inverted “V” collector contact surface keeps the contact shoes centered for improved collector tracking and more uniform brush wear

UNIVERSAL 8-BAR - to match existing systems

- Nylon hangers provide for double insulation against electrical grounding



Since 1911, Gleason Reel Corporation has been in the business of **CABLE & HOSE MANAGEMENT**. Our products are designed to convey and protect valuable cables and hoses that power and control moving machines of all types. They improve productivity and safety on the job by moving cables and hoses away from hazardous locations on machinery or the shop floor into a controlled environment. Whether you choose Reels for efficient storage and payout from virtually any angle, Festoon or Conductor Bar Systems for overhead applications or PowerTrak for protection on machinery in motion, your cables/hoses will last longer and provide better service with a cable management system from **GLEASON REEL CORPORATION - A HUBBELL COMPANY**.

APPLICATION PHOTOS

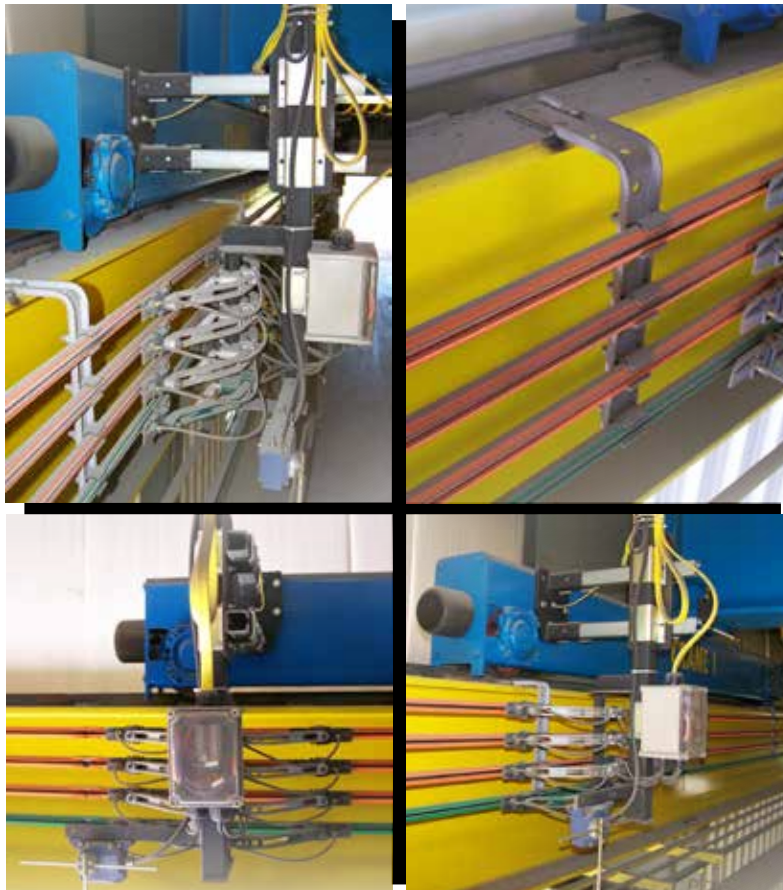

INSULATED CONDUCTOR BAR SYSTEM - INVERTED V-BAR
SHOWN IN OVERHEAD CRANE APPLICATION

CONDUCTOR BARS:

All INVERTED V-BAR and UNIVERSAL 8-BAR Conductor bar sections are roll formed from galvanized steel or electrolytic copper. These systems are amply sized and proportioned to carry the specified current without overheating. Internal joint connections assure full current carrying capacity without interfering with the free travel of the sliding collector contact shoes.

The standard insulating cover has a maximum temperature rating of 163°F (73°C).

CONDUCTOR JOINTS:

The joints for these systems consist of two connector pins made of plated steel for the galvanized steel conductor bar or electrolytic copper for the copper conductor bar. The connector pins are knurled to provide sufficient current carrying capacity and mechanical strength. The joint is designed to automatically align the conductor bar sections during installation.

CONDUCTOR SUPPORTS:

The standard hangers are a snap-in design made from nylon or polycarbonate. The maximum temperature rating is 400°F (204°C). Anchor hangers are available to control the movement of the conductor bar. They must be used on systems less than 30 feet long., at all transfer sections and runs to control expansion and contraction flow.

CONDUCTOR COLLECTORS:

Collector assemblies are offered in either single or double shoes types providing a continuous current carrying capacity of 40 amperes to 200 amperes. The contact shoes are supported by an insulating support that is spring loaded by an arm and body mechanism. All collectors are supplied with copper/graphite contacts for speeds up to 900 feet per minute on the INVERTED V-BAR and UNIVERSAL 8-BAR systems. For faster travel speeds, consult the factory.

NOTE: Current ratings are based on ambient temperature of 86°F (30°C).

ADVANTAGES

The INVERTED V-BAR systems offer superior collector tracking capabilities especially at higher speeds since the "V" shaped metal guides the collector contact shoes rather than the insulating cover as with all 8-Bar systems.

The INVERTED V-BAR systems can be mounted for bottom entry or side entry of the collector contact shoes.

INVERTED V-BAR systems are recommended for side entry (lateral mounted) systems over 8-Bar systems or systems with flat contact surfaces. Counter-balanced collectors are not required with the INVERTED V-BAR systems. The inward spring pressure on the contact shoe against the metal "V" contact surface fights off the downward gravitational pull to provide more uniform contact shoe wear.

The UNIVERSAL 8-BAR systems may be used interchangeably with other 1" bottom entry 8-bar systems.

Polycarbonate snap-in hangers provide an extra level of insulation as well as a rigid support for the conductor sections.

TYPICAL APPLICATIONS:

- Overhead Cranes
- Monorails
- Traveling Robots
- Aircraft Hanger Doors
- AS/RS Systems

TYPICAL SPECIFICATIONS

The Conductor Electrification System shall consist of thermoplastic enclosed conductor bar with mechanically tensioned collectors as manufactured by Gleason Reel Corporation.

The systems shall have a voltage rating of () Volts A.C. or D.C. () Volts and have a continuous current capacity of () Amperes per pole. When used as a Crane and Hoist Electrification System, the system shall be rated at () Amperes for continuous service and () Amperes for intermittent service. The full current carrying capacity of the system shall be maintained throughout.

The system shall permit longitude movement of the conductor bars in order to allow for unequal thermal expansion and contraction.

The system shall consist of standardized, interchangeable conductor bars (sections), power feeds, end caps, joint covers and collectors as called for in the plans.

The sections shall be made from roll formed galvanized steel or electrolytic copper and shall have a continuous "V" - groove, in the center, running the entire length. Conductors of this design shall be capable of carrying a current of 90 amperes and 110 amperes for steel sections and 250 amperes for copper sections continuously without overheating. The sections shall be insulated with a thermoplastic cover rated for ambient temperatures to 163°F (73°C).

The type of the conductor will be either 8-Bar or V-Bar configurations as called for in the plans.

The collectors shall consist of a lubricant impregnated contact shoe, mechanically supported by an insulating support assembly that is spring loaded by an arm and body mechanism.

Collector assemblies shall be mounted on a 1" square mounting post and allow for 3" collector spacing without staggering. The collector contact shoes shall have the unique concave shape for 8-Bar systems or an inverted "V" shape for V-Bar systems.

INVERTED V-BAR

CATALOG NO.	CONTINUOUS CURRENT RATING	INTERMITTENT CURRENT RATING	CONDUCTOR MATERIAL	LENGTH ft	WEIGHT lbs
V-90A	90 Ampere	135 Ampere	Galv. Steel	10' (3048mm)	4.5 (2.07 kg)
V-110A	110 Ampere	165 Ampere	Galv. Steel	10' (3048mm)	5.5 (2.50 kg)
V-250AL	250 Ampere	375 Ampere	Copper / Steel	10' (3048mm)	6.5 (2.95 kg)



UNIVERSAL 8-BAR

CATALOG NO.	CONTINUOUS CURRENT RATING	INTERMITTENT CURRENT RATING	CONDUCTOR MATERIAL	LENGTH ft	WEIGHT lbs
8-90A	90 Ampere	135 Ampere	Galv. Steel	10' (3048mm)	4.5 (2.07 kg)
8-110A	110 Ampere	165 Ampere	Galv. Steel	10' (3048mm)	5.5 (2.50 kg)
8-250AL	250 Ampere	375 Ampere	Copper / Steel	10' (3048mm)	6.5 (2.95 kg)



CONDUCTOR SECTIONS

Complete 10' (3028mm) long sections include two knurled connector pins and 163°F (73°C) rated thermoplastic insulating cover.

SPECIAL APPLICATIONS

Consult the factory for information and pricing on the following:

1. Curved conductor sections
2. Corrosion resistant - stainless steel conductors are available

CONDUCTOR SECTIONS



FOR 90, 110 OR 250 AMP SYSTEMS

CONDUCTION SUPPORTS

Thermoplastic snap-in type hangers and anchor hangers provide for an additional level of insulation as well as rigid support. of the conductor sections.

An anchor hanger should be used on systems less than 30' (9m) in length, at all transfer points/interlocks and where the conductor movement must be controlled or restricted.

Steel type hangers are also available.

Determine if the System is to be Side Entry (Lateral Mount) or Bottom Entry (Vertical Mount) and consult the Mounting Table (Right).

SYSTEM	MOUNTING	V-BAR	8-BAR
90 Amp	Side Entry*	4' (1220)	
90 Amp	Bottom Entry	5' (1220)	5' (1525)
110 Amp	Side Entry*	5' (1525)	
110 Amp	Bottom Entry	5' (1525)	5' (1525)
250 Amp	Side Entry*	4' (1220)	
250 Amp	Bottom Entry	5' (1220)	5' (1525)

*V-BAR is recommended on all Side Entry Systems.

NOTE:

Expansion sections must be staggered when conductor spacing is less than 3" (76mm).

INVERTED V-BAR and UNIVERSAL 8-BAR EXPANSION SECTIONS

CATALOG NO.		CONTINUOUS CURRENT RATING	INTERMITTENT CURRENT RATING	CONDUCTOR MATERIAL	LENGTH ft	WEIGHT lbs
V-BAR	8-BAR					
V-90E	8-90E	90 Ampere	135 Ampere	Galv. Steel	10' (3048mm)	6.8 (3.1 kg)
V-110E	8-110E	110 Ampere	165 Ampere	Galv. Steel	10' (3048mm)	9.5 (4.3 kg)
V-250EL	8-250EL	250 Ampere	375 Ampere	Copper / Steel	10' (3048mm)	10.5 (4.8 kg)

EXPANSION CONSIDERATIONS

CONDUCTOR MATERIAL	COEF. OF LINEAR EXPANSION PER °F (inches)	LINEAR EXPANSION PER 100' RUN PER 100°F TEMPERATURE CHANGE
Galv. Steel and Stainless Steel	.000007	.84"
Copper	.000009	1.08"

NOTE:

V-BAR and 8-BAR Expansion Sections have one 1.5" gap. Therefore, for every 100°F temperature change, install the expansion section as follows:

- Galvanized Steel and Stainless Steel Conductors - Every 180' (55m) ex: 1" center of 360' (110m) run.
- Copper Conductors - Every 140' (43m).
- All Systems - At building expansions.

FOR 90, 110 OR 250 AMP SYSTEMS

Hanger Assemblies for Inverted V-Bar Systems



CATALOG NO.	DESCRIPTION	WEIGHT lbs
V-H	Single Non-Metallic Snap-in (all sys)	.11 (.05 kg)

Anchor Hanger Assemblies for Inverted V-Bar Systems



CATALOG NO.	DESCRIPTION	WEIGHT lbs
V-HA	Non-Metallic Snap-in w/ Nylon Drive Rivet (all sys)	.12 (.05 kg)

Anchor Hangers should be used on all systems less than 30' (9m) in length, at all transfer points / interlocks and where the conductor movement must be controlled or restricted.

Power-Feed Assembly for Inverted V-Bar Systems



CATALOG NO.	DESCRIPTION	WEIGHT lbs
V-90PF	110 ampere (for 90 & 110 amp sys)	.33 (.15 kg)

End Caps for Inverted V-Bar Systems



CATALOG NO.	DESCRIPTION	WEIGHT lbs
V-EC	fits over exposed ends of conductor (all sys)	.04 (.02 kg)

Joint Cover for Inverted V-Bar Systems



CATALOG NO.	DESCRIPTION	WEIGHT lbs
V-JC	160°F (71°C) Orange (Standard)*	.02 (.01 kg)
V-JCHT	280°F (137°C) Yellow for High Temp *	.02 (.01 kg)
V-JC-G	Green for Ground Bar	.02 (.01 kg)

* Insulating joint covers are field installed over each joint to guard against accidental contact. One joint cover is required with each conductor section.

Isolation Piece



CATALOG NO.	DESCRIPTION	WEIGHT lbs
V-90IJ	for 90 amp system	.04 (.02 kg)
V-110IJ	for 110 amp system	.04 (.02 kg)

Used to interrupt power and isolate an area of the system.

Transfer Caps



CATALOG NO.	DESCRIPTION	WEIGHT lbs
V-TC	Molded plastic caps in lieu of end caps at transfer points (interlocks) along the conductor run (all systems)	.10 (.04 kg)

Connector Tool



CATALOG NO.	DESCRIPTION	WEIGHT lbs
V-T	Used to draw two conductor sections together (all systems)	2.8 (1.3 kg)

Pick-Up Guide Assembly

CATALOG NO.	SYSTEM	WEIGHT lbs
V-90EPG	for 90 amp system	1.50 (.68 kg)
V-110EPG	for 110 amp system	2.00 (.91 kg)
V-225EPG	for 250 amp system	2.00 (.91 kg)

Non-metallic guide with 19" (.5m) conductor bar, polycarbonate hangers and a transfer cap for guiding collector assemblies onto the conductor system after traveling free air.



8-BAR CONDUCTOR ACCESSORIES



FOR 90, 110 OR 250 AMP SYSTEMS



Hanger Assemblies for Universal 8-Bar Systems

CATALOG NO.	DESCRIPTION	WEIGHT lbs
8-H	Single Non-Metallic Snap-in (all sys)	.11 (.05 kg)
8-SPH	Single Spring Steel (all sys)	.04 (.02 kg)



Anchor Hanger Assemblies for Universal 8-Bar Systems

CATALOG NO.	DESCRIPTION	WEIGHT lbs
8-HA	Non-Metallic Snap-in w/ Nylon Drive Rivet (all sys)	.12 (.06 kg)

Anchor Hangers should be used on all systems less than 30' (9m) in length, at all transfer points / interlocks and where the conductor movement must be controlled or restricted.



Power-Feed Assembly for Universal 8-Bar Systems

CATALOG NO.	DESCRIPTION	WEIGHT lbs
8-90PF	110 ampere (for 90 & 110 amp sys)	.30 (.14 kg)
8-250PF	250 ampere (for 250 amp sys)	.53 (.24 kg)



End Caps for Universal 8-Bar Systems

CATALOG NO.	DESCRIPTION	WEIGHT lbs
8-EC	fits over exposed ends of conductor (all sys)	.04 (.02 kg)



Joint Cover for Universal 8-Bar Systems

CATALOG NO.	DESCRIPTION	WEIGHT lbs
8-JC	160°F (71°C) Orange (Standard)*	.02 (.01 kg)
8-JCHT	280°F (137°C) Yellow for High Temp *	.02 (.01 kg)
8-JC-G	Green for Ground Bar	.02 (.01 kg)

* Insulating joint covers are field installed over each joint to guard against accidental contact. One joint cover is required with each conductor section.



Isolation Piece

CATALOG NO.	DESCRIPTION	WEIGHT lbs
8-90IPK	for 90 amp system	.04 (.02 kg)
8-110IPK	for 110 amp system	.04 (.02 kg)

Used to interrupt power and isolate an area of the system.



Transfer Caps

CATALOG NO.	DESCRIPTION	WEIGHT lbs
8-TC	Molded plastic caps in lieu of end caps at transfer points (interlocks) along the conductor run (all systems)	.10 (.04 kg)



Connector Tool

CATALOG NO.	DESCRIPTION	WEIGHT lbs
8-T	Used to draw two conductor sections together (all systems)	2.8 (1.3 kg)

Pick-Up Guide Assembly

CATALOG NO.	SYSTEM	WEIGHT lbs
8-90EPG	for 90 amp system	1.50 (.68 kg)
8-110EPG	for 110 amp system	2.00 (.91 kg)
8-250EPG	for 250 amp system	2.00 (.91 kg)

Non-metallic guide with 19" (.5m) conductor bar, polycarbonate hangers and a transfer cap for guiding collector assemblies onto the conductor system after traveling free air.



Mainline / Top Running Crane Applications -Web Mounting (Bottom Entry Systems)

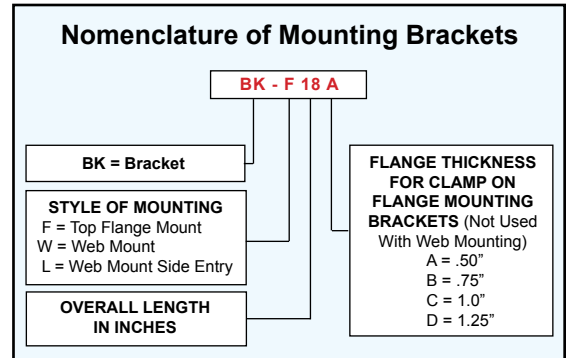
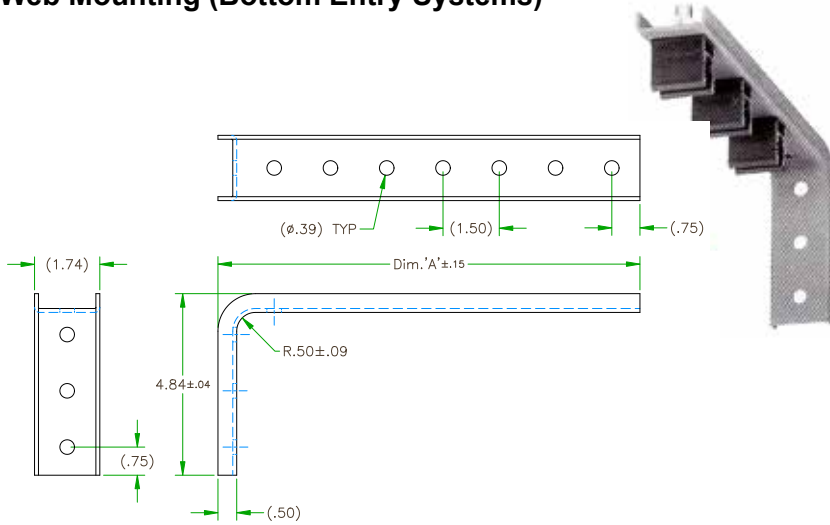

NOTE: Hangers are ordered separately.

CATALOG NO.	X-DIMENSION	WEIGHT lbs
BK-W15	11¼" (286mm)	1.25 (.57 kg)
BK-W18	14¼" (362mm)	1.50 (.68 kg)
BK-W21	17¼" (438mm)	1.75 (.80 kg)
BK-W24	20¼" (514mm)	2.15 (.98 kg)

Monorail / Underhung Crane Applications -Flange Mounting (Bottom Entry Systems) -Weld-on Type or Clamp-on Type

BK-F18A with V-H Hangers

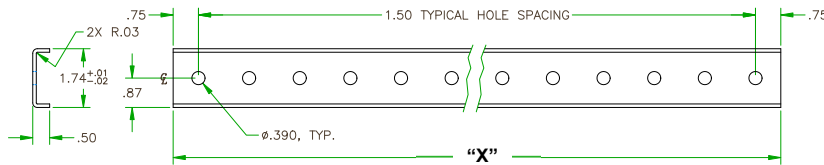

CATALOG NO.	X-DIMENSION	WEIGHT lbs
BK-F18	18" (457mm)	1.50 (.68 kg)
BK-F21	21" (533mm)	1.75 (.80 kg)
BK-F24	24" (610mm)	2.00 (.91 kg)

NOTE: Hangers are ordered separately.

Side Entry Systems -Web Mounting Bracket (Side Entry Systems)

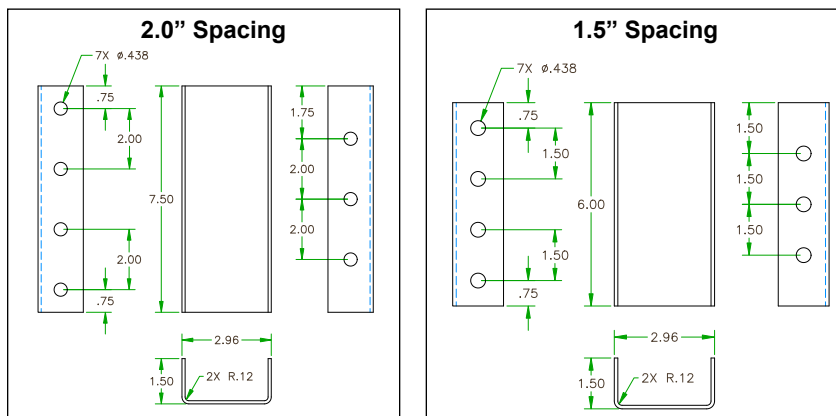

BK-L4

CATALOG NO.	No. CONDUCTORS	WEIGHT lbs
BK-L4	4 (1.5" spacing)	2.00 (.91 kg)
BK-L3-2	3 (2.0" spacing)	2.00 (.91 kg)
BK-L4-2	4 (2.0" spacing)	2.70 (1.22 kg)

COLLECTORS



FOR 90, 110 OR 250 AMP SYSTEMS

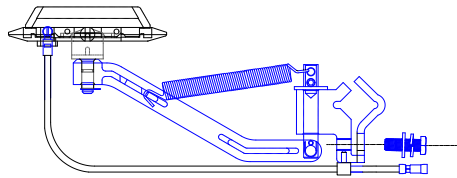

40 Amp V-Bar Collector Assembly
V-40SC

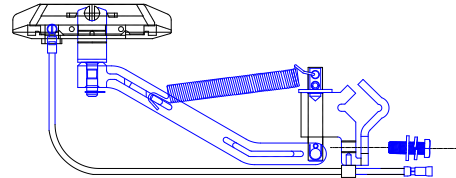

40 Amp 8-Bar Collector Assembly
C-40SC

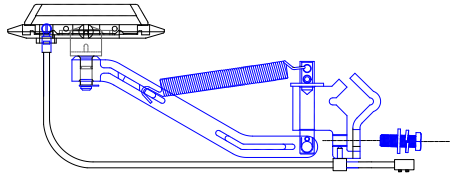

100 Amp V-Bar Collector Assembly
V-100SC

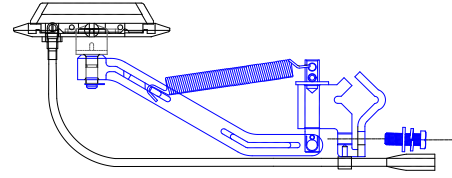

100 Amp 8-Bar Collector Assembly
C-100SC

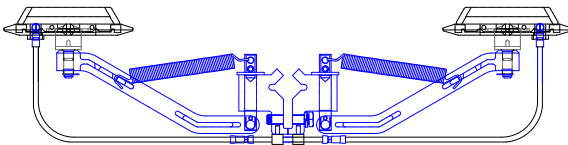

80 Amp Tandem V-Bar Collector Assembly
V-80STC

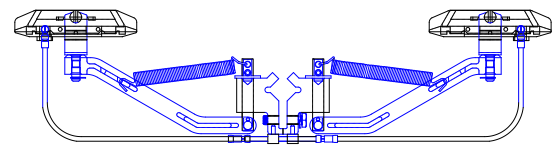

80 Amp Tandem 8-Bar Collector Assembly
C-80STC

DESCRIPTION	STANDARD	
	V-BAR	8-BAR
COMPLETE SINGLE SHOE COLLECTORS Minimum Spacing Side-By-Side Minimum Spacing Staggered 40 Amp Bottom Entry (Vertical Mount) 100 Amp Bottom Entry (Vertical Mount) 40 Amp Side Entry (Lateral Mount) 100 Amp Side Entry (Lateral Mount)	2.0" (51mm) 1.5" (38mm) V-40SC V-100SC V-40SC V-100SC	2.0" (51mm) 1.5" (38mm) C-40SC C-100SC None None
COMPLETE DOUBLE SHOE COLLECTORS Minimum Spacing Side-By-Side 80 Amp Bottom Entry (Vertical Mount) 200 Amp Bottom Entry (Vertical Mount) 80 Amp Side Entry (Lateral Mount) 200 Amp Side Entry (Lateral Mount)	2.0" (51mm) V-80STC V-200STC V-80STC V-200STC	2.0" (51mm) C-80STC C-200STC None None
COLLECTOR HEADS (Shoe, Holder, Clevis & Pigtail Assy) 40 Amp 100 Amp	V-40SCH-1 V-100SCH-1	C-40SCH-1 C-100SCH-1
CONTACT SHOES 40 Amp & 100 Amp (4-3/4" long)	V-100CS1	C-100CS1
CONTACT SHOE HOLDERS	C-VCSH-6	C-CSH-6
COLLECTOR EXTENSION SPRINGS	C-SCS	C-SCS
COLLECTOR ARM CASTINGS	C-SCA	C-SCA
COLLECTOR MOUNTING POSTS 1" Square Bar Welded to Mounting Plate	All Collectors #C-CMP	

1. VOLTAGE DROP CALCULATIONS

- A. Single Phase - A.C.
Voltage Drop = 2 x Amps x Zac x distance in feet from power feed.
- B. Three Phase - A.C.
Voltage Drop = 1.732 x Amps x Zac x distance in feet from power feed.
- C. Direct Current
Voltage Drop = 2 x Amps x Rdc x distance in feet from power feed.

SYSTEM	D.C. RESISTANCE (Rdc.)	A.C. IMPEDANCE* (Z ac)
90 Amp	.00073 ohms / Ft.	.0011 ohms / Ft.
	.0025" / MTR	.0279" / MTR
110 Amp	.0005 ohms / Ft.	.0008 ohms / Ft.
	.0127" / MTR	.0203" / MTR
250 Amp	.00008 ohms / Ft.	.0001 ohms / Ft.
	.00203" / MTR	.0025" / MTR
	.0127" / MTR	.0203" / MTR

2. HORSEPOWER CONVERSION TO AMPS

Induction-Type Squirrel-Cage and Wound Rotor Motors

SINGLE-PHASE AC 60 CYCLES AMPERES		
H.P.	115V	230V
1	16	8
1½	20	10
2	24	12
3	34	17
5	56	28
7½	80	40
10	100	50

THREE-PHASE AC 60 CYCLES AMPERES				DIRECT CURRENT AMPERES		
H.P.	220V	440V	550V	H.P.	115V	230V
1	3.5	1.8	1.4	1	9.6	4.8
1½	5	2.5	2	1½	13.2	6.6
2	6.5	3.3	2.6	2	17	8.5
3	9	4.5	4	3	25	12.5
5	15	7.5	6	5	40	20
7½	22	11	9	7½	58	29
10	27	14	11	10	78	38
15	40	20	16	15	112	56
20	52	26	21	20	148	74
25	64	32	26	25	184	92
30	78	39	31	30	220	110
40	104	52	51	40	292	146
50	125	63	50	50	364	180
60	149	75	60	60	436	215
75	180	90	72	75	540	268
100	246	123	98	100	-	357
125	310	155	124	125	-	443
150	360	180	144	150	-	-
200	480	240	195	200	-	-

The ampere rating of motors vary somewhat depending on the type of motor. The data tabulated can be considered average for 1800 R.P.M. normal torque motors. For slower speed motors, the ampere ratings may be approximately 10% to 50% higher. For the case of high-torque squirrel-cage motors, the ampere rating will be at least 10% higher than the values given above the corresponding 220-volt ratings shown. For more exact data, refer to motor nameplate ratings.

TYPICAL 3-CONDUCTOR SYSTEM LAYOUT

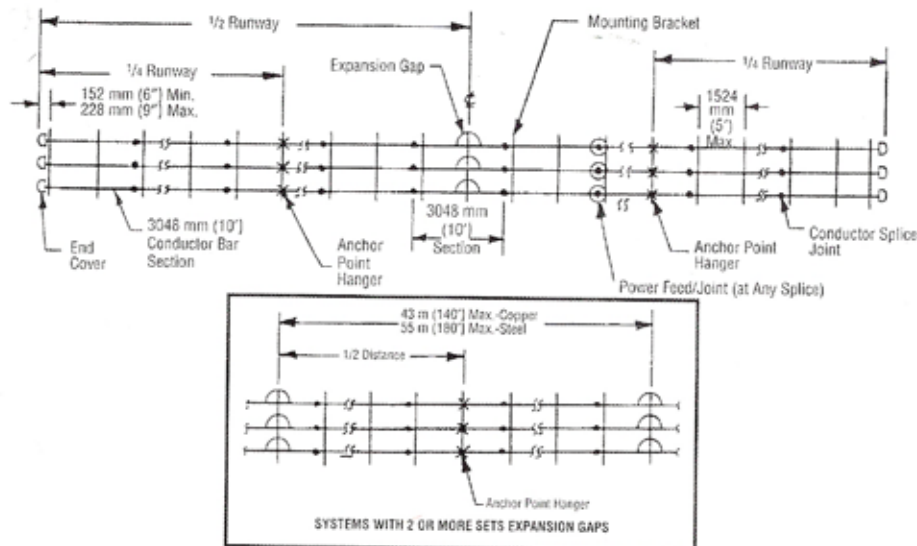

TYPICAL INSTALLATIONS

**BOTTOM ENTRY
(WEB MOUNT)**

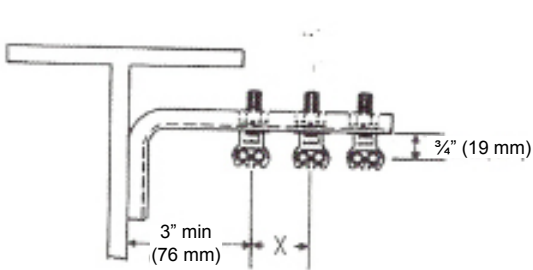

**SIDE ENTRY
(WEB MOUNT)**

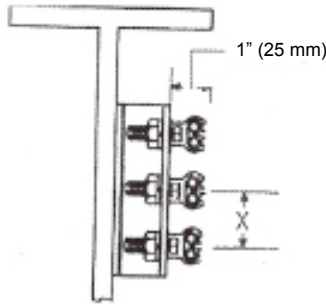

**BOTTOM ENTRY
(FLANGE MOUNT)
CLAMP ON TYPE**

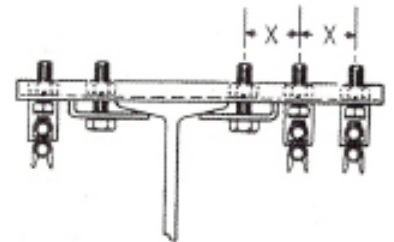
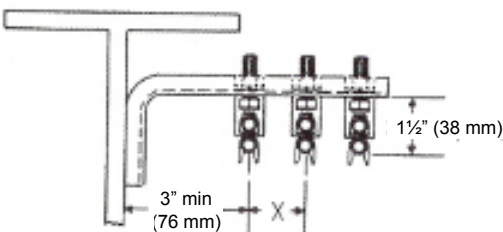
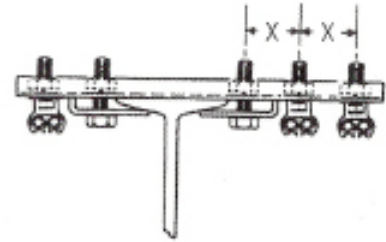

APPLICATION	X DIMENSION			
	V-BAR		8-BAR	
	Minimum	Recommended	Minimum	Recommended
Collectors:				
Adjacent	2.0" (51mm)	3.0" (76mm)	2.0" (51mm)	3.0" (76mm)
Staggered	1.5" (38mm)	1.5" (38mm)	1.5" (38mm)	1.5" (38mm)
Power Feeds:				
Adjacent	2.0" (51mm)	3.0" (76mm)	2.0" (51mm)	3.0" (76mm)
Staggered	1.5" (38mm)	1.5" (38mm)	1.5" (38mm)	1.5" (38mm)
Expansion Assemblies:				
Adjacent	2.0" (51mm)	3.0" (76mm)	2.0" (51mm)	3.0" (76mm)
Staggered	2.0" (51mm)	2.0" (51mm)	2.0" (51mm)	2.0" (51mm)
When Insulators Are Used:	2.0" (51mm)	3.0" (76mm)	2.0" (51mm)	3.0" (76mm)

INVERTED V-BAR

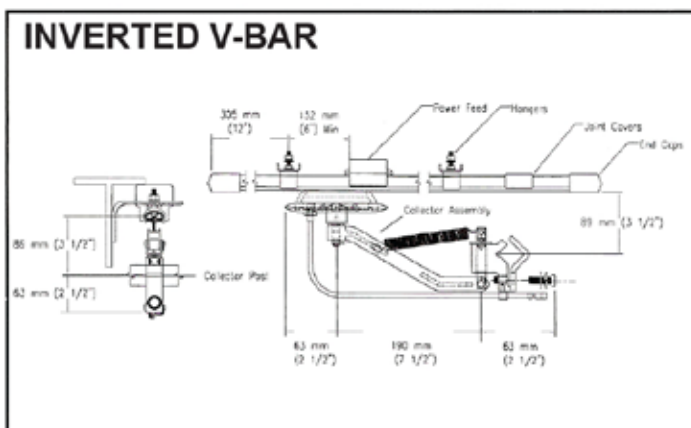

UNIVERSAL 8-BAR

